

L2+ Managed Gigabit Switch

WGSW-24040HP4

Quick Installation Guide

Table of Contents

1. Package Contents	3
2. Requirements	4
3. Terminal Setup	5
3.1 Logging on to the Console	6
3.2 Configuring IP Address	8
3.3 Storing Current Switch Configuration	9
4. Starting Web Management	10
4.1 Logging on to the Managed Switch	11
4.2 Saving Configuration	15
5 Recovering Back to Default Configuration	16
6. Customer Support	17

1. Package Contents

Thank you for purchasing PLANET WGSW-24040HP4 Managed Gigabit Switch. The description of the WGSW-24040HP4 is shown below:

Model	TP Port	Fiber Port	Combo Port	PoE Budget
WGSW-24040HP4	24	-	4	440W

“Managed Switch” is used as an alternative name in this Quick Installation Guide.

Open the box of the Managed Switch and carefully unpack it. The box should contain the following items:

- The Managed Switch x 1
- QR Code Sheet x 1
- DB9 to RS232 Cable x 1
- Rubber Feet x 1
- Two Rack-mounting Brackets with Attachment Screws x 1
- Power Cord x 1
- SFP Dust-proof Caps x 4

If any item is found missing or damaged, please contact your local reseller for replacement.

2. Requirements

- **Workstations** running Windows 7/8/10/11, macOS 10.12 or later, Linux Kernel 2.6.18 or later, or other modern operating systems are compatible with TCP/IP Protocols.
- Workstations are installed with Ethernet NIC (Network Interface Card)
- **Serial Port Connection** (Terminal)
 - The above Workstations come with COM Port (DB9) or USB-to-RS232 converter.
 - The above Workstations have been installed with terminal emulator, such as Tera Term, PuTTY or Hyper Terminal included in Windows XP/2003.
 - Serial cable -- one end is attached to the RS232 serial port, while the other end to the console port of the Managed Switch.
- **Ethernet Port Connection**
 - Network cables -- Use standard network (UTP) cables with RJ45 connectors.
 - The above PC is installed with Web browser.



Note

It is recommended to use Google Chrome, Microsoft Edge or Firefox to access the Managed Switch. If the Web interface of the Managed Switch is not accessible, please turn off the anti-virus software or firewall and then try it again.

3. Terminal Setup

To configure the system, connect a serial cable to a COM port on a PC or notebook computer and to DB9 type of serial port of the Managed Switch.

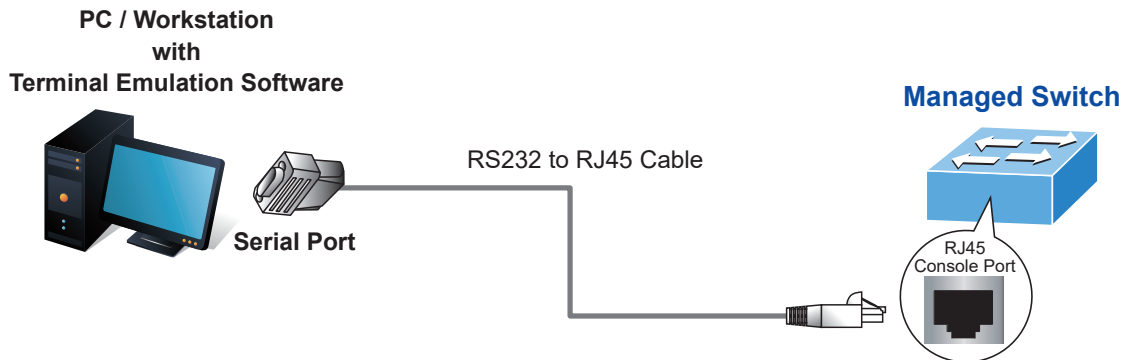

Figure 3-1: Managed Switch Console Connectivity

A terminal program, such as Tera Term or PuTTY, is required to make the software connection to the Managed Switch.

1. Run terminal program on the OS.
2. When the following screen appears, make sure that the COM port should be configured as:
 - Baud: 115200
 - Data bits: 8
 - Parity: None
 - Stop bits: 1
 - Flow control: None

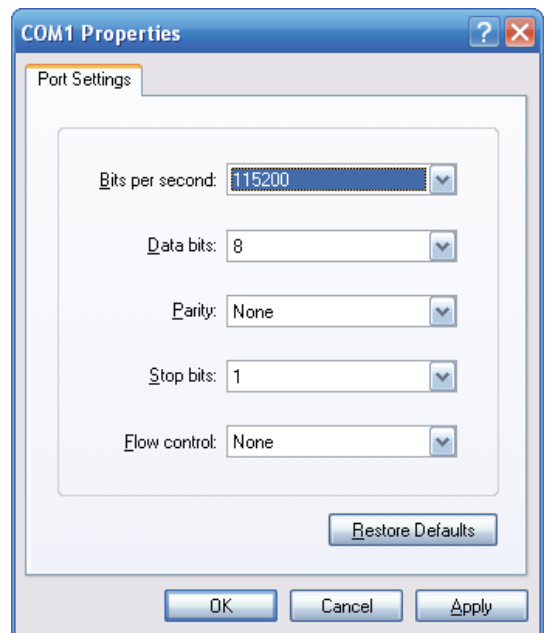

Figure 3-2: COM Port Configuration

3.1 Logging on to the Console

Once the terminal is connected to the device, power on the Managed Switch, and the terminal will display "running testing procedures". Then, the following message asks to log in user name and password. The factory default user name and password are shown as follows and the login screen in Figure 3-3 appears.



Note

The following console screen is based on the firmware version before April of 2024.

Username: **admin**

Password: **admin**

```
Username: admin
Password:
WGSW-24040# █
```

Figure 3-3: Managed Switch Console Login Screen

The user can now enter commands to manage the Managed Switch. For a detailed description of the commands, please refer to the following chapters.



Note

1. For security reason, please change and memorize the new password after this first setup.
2. Only accept command in lowercase letter under console interface.



The following console screen is based on the firmware version of **April of 2024 or after**.

User name: **admin**

Password: **sw + the last 6 characters of the MAC ID in lowercase**

Find the MAC ID on your device label. The default password is "sw" or "mc" followed by the last six lowercase characters of the MAC ID.

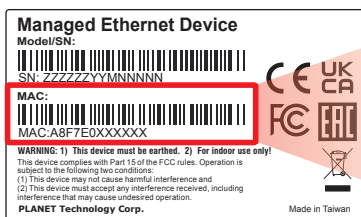

MAC ID: A8F7E0XXXXXX
Default Password: swxxxxxx
("x" means the last 6 digits of the MAC address.
All characters should be in lowercase.)

Figure 3-4: Managed Switch MAC ID Label

Enter the default username and password, then set a new password according to the rule-based prompt and confirm it. Upon success, press any key to return to the login prompt. Log in with "admin" and the "new password" to access the CLI.

```
Generating file "startup-config.cfg"
==== Generating Startup Config File

==== Backup Config File Synchroniz
==== Backup Config File Synchroniz

Press any key to continue
Username: admin
Password: b*77*9*****
You are required to change and store
Please store your new password in a
Once configured, also store a copy o
Password: The password must contain
(New) Password: *****
Verify (New) Password: *****
Success.
Press any key to continue
Username: admin
Password: *****
WGSW-24040#
```

Figure 3-5: Create a New Password and Login Again

The user can now enter commands to manage the Managed Switch. For a detailed description of the commands, please refer to the following chapters.

3.2 Configuring IP Address

The Managed Switch is shipped with default IP address shown below.

```
IP Address: 192.168.0.100  
Subnet Mask: 255.255.255.0
```

To check the current IP address or modify a new IP address for the Managed Switch, please use the procedures as follows:

■ Show the current IP Address

1. At the “#” prompt, enter “**show ip interface brief**”.
2. The screen displays the current IP address as shown in Figure 3-6.

```
Username: admin  
Password:  
WGSW-24040# show ip interface brief  
Interface  Address                      Method  Status  
-----  -  
VLAN 1    192.168.0.100/24              Manual  UP  
WGSW-24040# █
```

Figure 3-6: IP Information Screen

■ Configuring IP Address

3. At the “#” prompt, enter the following command and press <Enter> as shown in Figure 3-7.

```
WGSW-24040 # configure terminal  
WGSW-24040 (config)# interface vlan 1  
WGSW-24040 (config-if-vlan)# ip address 192.168.1.100 255.255.255.0
```

```
WGSW-24040 (config)# exit  
WGSW-24040# configure terminal  
WGSW-24040 (config)# interface vlan 1  
WGSW-24040 (config-if-vlan)# ip address 192.168.1.100 255.255.255.0  
WGSW-24040 (config-if-vlan)# █
```

Figure 3-7: Configuring IP Address Screen

The previous command would apply the following settings for the Managed Switch.

IP Address: **192.168.1.100**
Subnet Mask: **255.255.255.0**

4. Repeat step 1 to check if the IP address has changed.

If the IP is successfully configured, the Managed Switch will apply the new IP address setting immediately. You can access the Web interface of the Managed Switch through the new IP address.

3.3 Storing Current Switch Configuration

In the Managed Switch, the running configuration sequence `running-config` can be saved from the RAM to FLASH by **"copy"** command, so that the running configuration sequence becomes the start-up configuration file, which is called configuration save.

At the `"#"` prompt, enter the following command and press `<Enter>`.

```
# copy running-config startup-config
```

```
WGSW-24040# copy running-config startup-config
Building configuration...
do not reset or power off the device!
% Saving 4565 bytes to flash:startup-config
WGSW-24040#
```

Figure 3-8: Saving Current Configuration Command Screen



Note

If you are not familiar with the console command or the related parameter, enter **"help"** anytime in console to get the help description.

4. Starting Web Management

The following shows how to start up the **Web Management** of the Managed Switch. Note the Managed Switch is configured through an Ethernet connection. Please make sure the manager PC must be set to the same **IP subnet address**.

For example, the default IP address of the Managed Switch is **192.168.0.100**, then the manager PC should be set to **192.168.0.x** (where x is a number between 1 and 254, except 100), and the default subnet mask is 255.255.255.0.

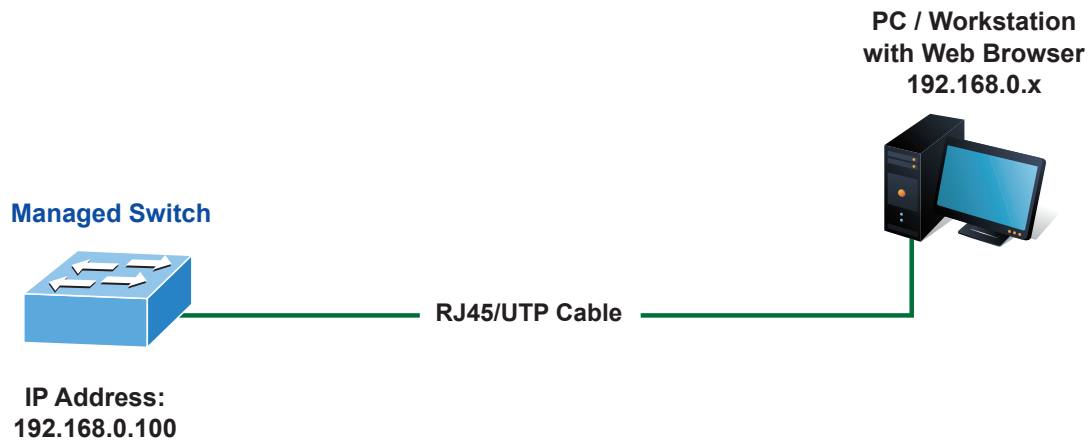

Figure 4-1: IP Management Diagram

4.1 Logging on to the Managed Switch

1. Use Chrome 98.0.xxx or above Web browser and enter IP address **https://192.168.0.100** (the factory default IP address or the one that you have just changed in console) to access the Web interface.



Note

The following web screen is based on the firmware version before **April of 2024**.

2. When the following dialog box appears, please enter the default user name and password "**admin**" (or the password you have changed via console). The login screen in Figure 4-2 appears.

Default IP Address: **192.168.0.100**

Default Username: **admin**

Default Password: **admin**

Authentication required

https://192.168.0.100
Your connection to this site is not private

Username

Password

Log in Cancel

Figure 4-2: Login Screen

3. After entering the password, the main screen appears as Figure 4-6 shows.



The following web screen is based on the firmware version before **April of 2024**.

- When the following dialog box appears, please enter the default user name **"admin"** and the password. Refer to **Section 3.1** to determine your initial login password.

Default IP Address: **192.168.0.100**

Default User Name: **admin**

Default Password: **sw + the last 6 characters of the MAC ID in lowercase**

- Find the MAC ID on your device label. The default password is "sw" or "mc" followed by the last six lowercase characters of the MAC ID.

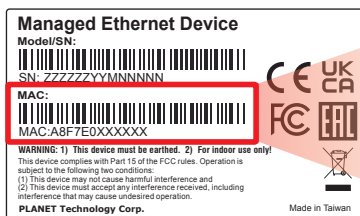

MAC ID: A8F7E0XXXXXX

Default Password: swxxxxxx

("x" means the last 6 digits of the MAC address.

All characters should be in lowercase.)

Figure 4-3: Managed Switch MAC ID Label

Authentication required

https://192.168.0.100

Your connection to this site is not private

Username

Password

Figure 4-4: Login Screen

6. After logging in, you will be prompted to change the initial password to a permanent one.

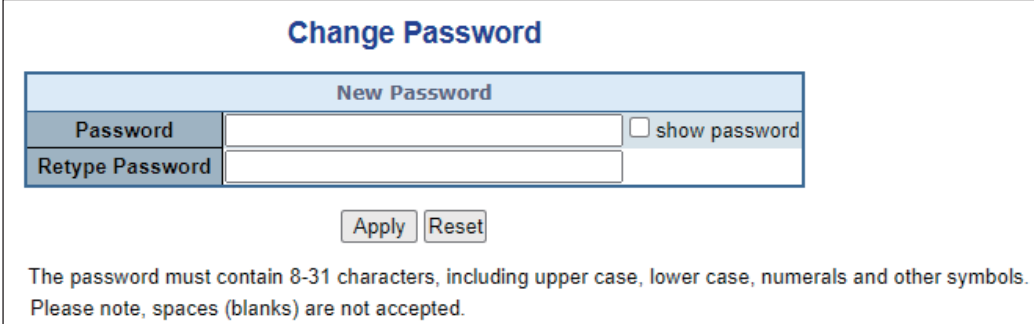

The image shows a web form titled "Change Password". It has a header "New Password" and two input fields: "Password" and "Retype Password". There is a checkbox labeled "show password" next to the "Password" field. Below the fields are "Apply" and "Reset" buttons. A note at the bottom states: "The password must contain 8-31 characters, including upper case, lower case, numerals and other symbols. Please note, spaces (blanks) are not accepted."

Figure 4-5: Create a New Password

7. Enter the default username and password, then set a new password according to the rule-based prompt and confirm it. Upon success, press any key to return to the login prompt. Log in with "admin" and the "new password" to access the Web interface.



Figure 4-6: Web Main Screen of Managed Switch

The Switch Menu on the top of the Web page lets you access all the commands and statistics the Managed Switch provides. The Switch Menu always contains one or more buttons, such as **“Refresh”**, **“Save”**, **“Help”** and **“Logout”**.



Figure 4-7: Switch Menu

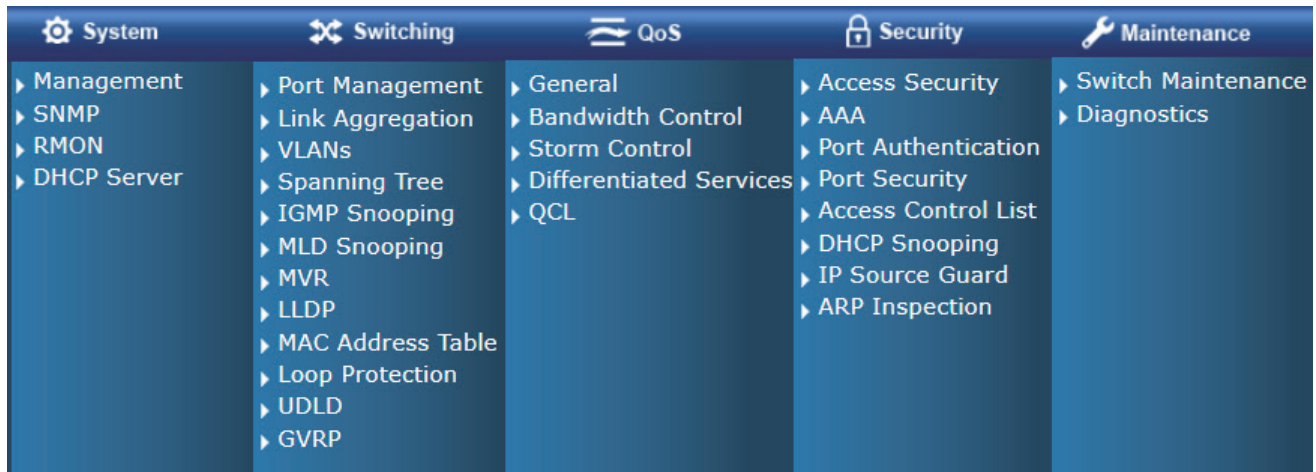

Figure 4-8: Switch Menu – System



Note

If you are not familiar with Switch functions or the related parameter, press **“Help icon”** anytime on the Web page to get the help description.

Now, you can use the Web management interface to continue the Switch management or manage the Switch by console interface.

Please refer to the user’s manual for more.

4.2 Saving Configuration

To save all applied changes and set the current configuration as a startup configuration on the Web user interface, the startup-configuration file will be loaded automatically across a system reboot.

1. Click the **Save** icon on the top Switch Menu bar.

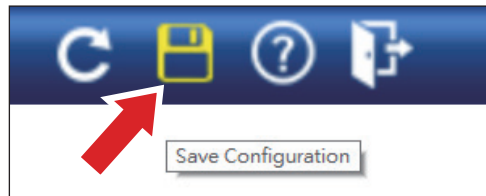
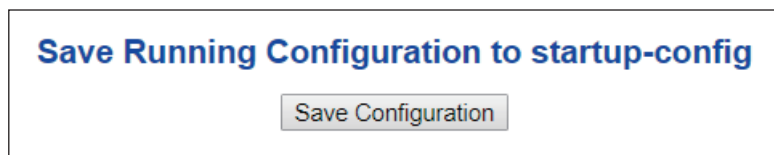

Figure 4-9: Save Config -- Hot Key

2. Press the **"Save Configuration"** button.



3. Or the other way to save the setting is to Click **Maintenance, Save Startup Config**.

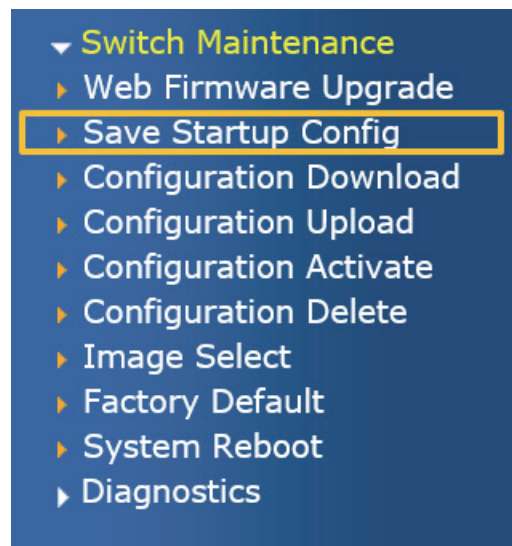

Figure 4-10: Save Config -- Maintenance

5 Recovering Back to Default Configuration

■ IP address has been changed or admin password has been forgotten –

To reset the IP address to the default IP Address **"192.168.0.100"** and the user name password to factory default mode (default password is admin or sw + the last 6 characters of the MAC ID in lowercase), press the hardware reset button on the front panel for about 10 seconds. After the device is rebooted, you can log in the management Web interface within the same subnet of 192.168.0.xxx.

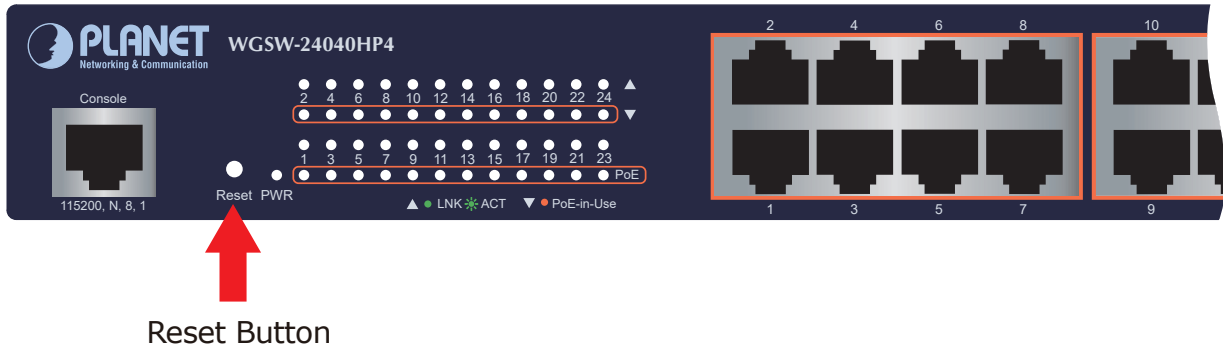

Figure 5-1: WGSW-24040HP4 Reset Button

6. Customer Support

Thank you for purchasing PLANET products. You can browse our online FAQ resource and User's Manual on PLANET Web site first to check if it could solve your issue. If you need more support information, please contact PLANET switch support team.

PLANET online FAQs:

<https://www.planet.com.tw/en/support/faq>

Switch support team mail address:

support@planet.com.tw

WGSW-24040 Series and WGSW-20160HP User's Manual:

<https://www.planet.com.tw/en/support/downloads?&method=keyword&keyword=WGS&view=3#list>



(Please select your switch model name from the drop-down menu of Product Model.)

Copyright © PLANET Technology Corp. 2024.

Contents are subject to revision without prior notice.

PLANET is a registered trademark of PLANET Technology Corp.

All other trademarks belong to their respective owners.