

**Industrial IP67 1-Port 802.3bt PoE++ to  
2-Port 802.3at/bt Gigabit PoE Extender**

**IPOE-E302**

**User's Manual**



# Table of Contents

1. Package Contents.....	3
2. Hardware Introduction .....	4
2.1 Product Outlook.....	4
2.2 802.3bt PoE++ Input Port .....	4
2.3 802.3at/bt PoE+ Output Port .....	5
2.4 LED Indicators.....	5
3. Installation .....	6
3.1 Installing Cable Gland with RJ45 UTP Cable .....	6
3.2 Connecting Waterproof Cable Kit to the Outdoor PoE Extender .....	6
3.3 Wall-mount Installation .....	9
3.4 Grounding the Device.....	10
3.5 Connecting IPOE-E302 to PSE.....	11
3.6 Connecting IPOE-E302 to PD .....	11
4. Power over Ethernet Budget.....	13
5. Product Specifications .....	16
6. Customer Support .....	19

## 1. Package Contents

Thank you for purchasing PLANET Industrial IP67 1-port 10/100/1000T 802.3bt PoE++ to 2-port 10/100/1000T 802.3at/bt PoE++ Extender, IPOE-E302. In the following sections, the term "**Outdoor PoE Extender**" means the IPOE-E302.

Open the box of the Industrial PoE Extender and carefully unpack it. The box should contain the following items:

IPOE-E302 x 1	M22 Waterproof Cable Gland x 3	Spanner x 1
		
QR code sheet x 1	Mounting Kit x 1	Ground Wire x 1
		

If any of these are missing or damaged, please contact your dealer immediately; if possible, retain the carton including the original packing material, and use them again to repack the product in case there is a need to return it to us for repair.

Remarks: The color of the ground wire is different according to the batch, but its wire specifications meet the standard.

## 2. Hardware Introduction

This section describes the functionalities of the Outdoor PoE Extender's components.

### 2.1 Product Outlook

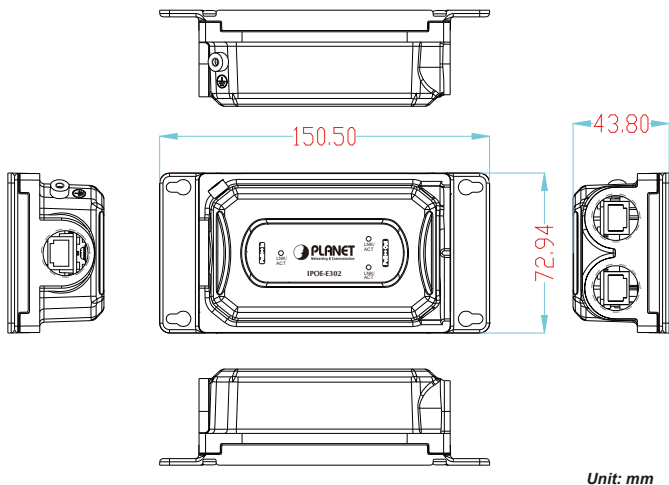

Figure 2-1: IPOE-E302 product outlook

### 2.2 802.3bt PoE++ Input Port

Figure 2-2 shows the PoE++ input port side of the IPOE-E302

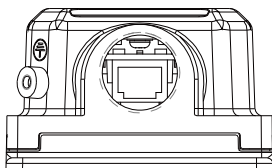

Figure 2-2: IPOE-E302 PoE++ Input Port Side

## 2.3 802.3at/bt PoE+ Output Port

Figure 2-3 shows the two PoE+ output ports side of the IPOE-E302.

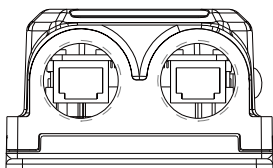

Figure 2-3: IPOE-E302 PoE++ Output ports side

## 2.4 LED Indicators

LED	Color	Function
LNK/ACT	Green	<b>Lights</b> to indicate the port is linked up at 10/100/1000Mbps.
		<b>Blinks</b> to indicate that the IPOE-E302 is actively sending or receiving data over that port.

### 3. Installation

This section describes how to install the Outdoor PoE Extender and make connections to it. Please read the following sections and perform the procedure in the order being presented.

#### 3.1 Installing Cable Gland with RJ45 UTP Cable

The cable gland consists of the following

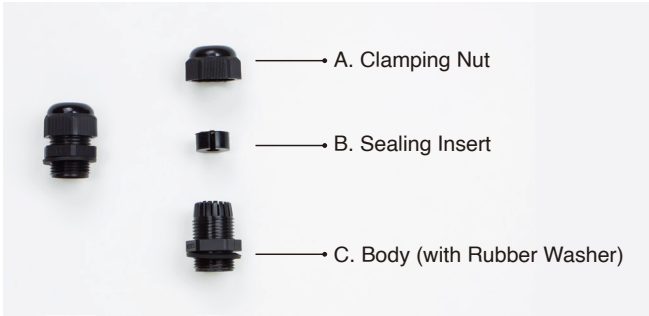

#### 3.2 Connecting Waterproof Cable Kit to the Outdoor PoE Extender

**Step 1:** Turn clockwise to tighten the **gland body** connected to the Outdoor PoE Extender.



**Step 2:** Plug the RJ45 connector into the connector of the **PoE++ In** port.

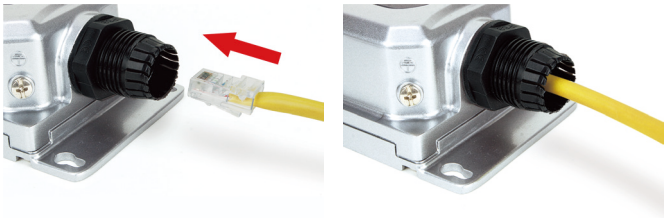

**Step 3:** Insert the **sealing insert** into the cable gland body.

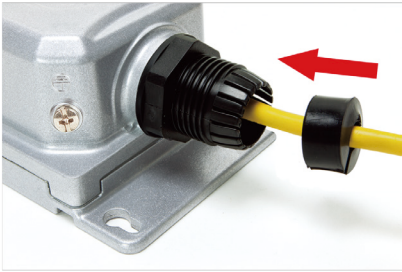

**Step 4:** Attach the **clamping nut** to the cable gland to complete the cable assembly.

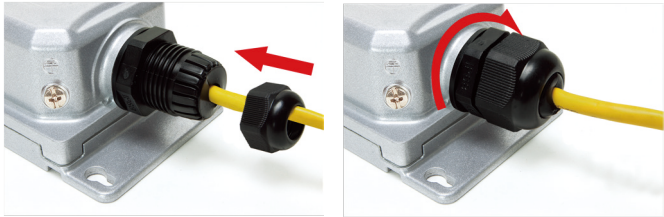

Caution

Make sure the clamping nut is tightly attached to the cable gland body and the sealing insert is squeezed tightly.

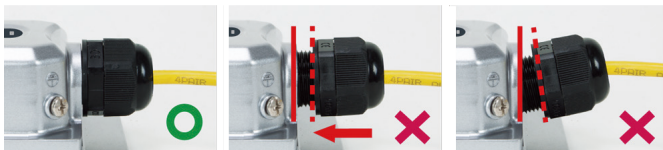

**Step 5:** Repeat **Steps 1 to 4** for two **PoE++ Out** ports.

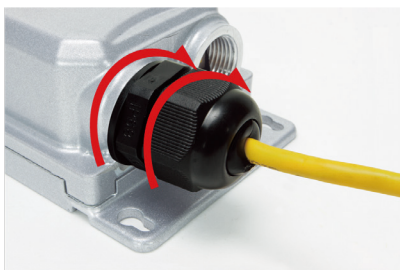





### Note

1. Use only the waterproof cable gland provided in the package of the IPOE-E302.
2. If the above installation procedure is not properly followed, the warranty will be invalidated.

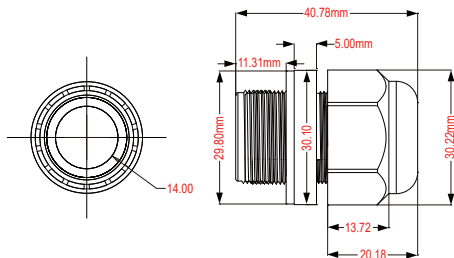

3. If the waterproof cable gland is found missing or damaged, please contact your local reseller where you purchased from.
4. Never use any waterproof cable gland that is not purchased from PLANET or doesn't have the same dimensions of the IPOE-E302; it will damage the device permanently.

## 3.3 Wall-mount Installation

To install the Outdoor PoE Extender on the wall, please follow the instructions described below.

**Step 1:** Find the wall that you want to mount the Outdoor PoE Extender on.

**Step 2:** Refer to the picture below to screw the four screws on the wall.

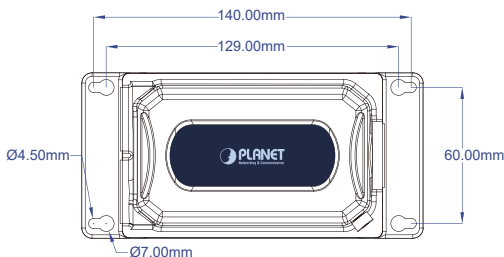

**Step 3:** Use a screwdriver to screw them into the wall.



### 3.4 Grounding the Device

Users **MUST** complete grounding wired with the device; otherwise, a sudden lightning could cause fatal damage to the device.

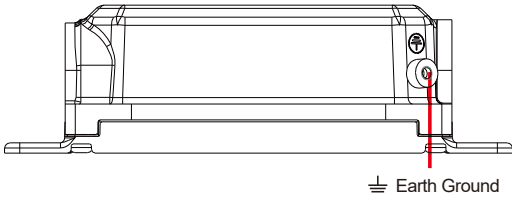

Note

EMD (Lightning) DAMAGE IS NOT COVERED UNDER WARRANTY.

### 3.5 Connecting IPOE-E302 to PSE

The Outdoor PoE Extender has three RJ45 ports of which one is the **PoE++ In** port connected to the PSE and the other two are **PoE+/ PoE++ Out** ports connected to the PDs.

**Step 1:** Connect a standard Cat5e/6 UTP cable from a remote **PSE**, such as PoE switch, to the **"PoE++ In"** port of the IPOE-E302.

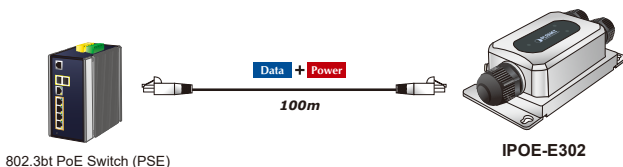

**Step 2:** The PSE delivers both Ethernet Data and PoE power over UTP cable to the IPOE-E302 and the **"LAN"** LED will be lit steadily.



#### Note

1. If the LED is not lit, please check the remote PSE or the cable connecting to a PC or a network device to see if the cable is correct. Or with an 802.3at/bt device such as the target PD, check whether the power injection is correct.
2. Never connect any **non-standard** PoE PSE to the IPOE-E302; it will damage the device permanently.

### 3.6 Connecting IPOE-E302 to PD

**Step 1:** Connect the additional Cat5e/6 cable from the **PoE++ Out** of the IPOE-E302 to a remote **PD**.

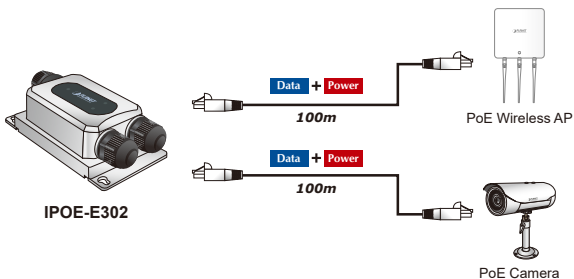

**Step 2:** The **PoE++ Out** port is also the power injector which transmits DC voltage to the Cat5e/6 cable and transfer data and power simultaneously between the PSE and PD.

**Step 3:** Once the IPOE-E302 detects the existence of an IEEE 802.3at/bt device or Ethernet device, the **LAN** LED indicator will be lit steadily, showing it is providing power.

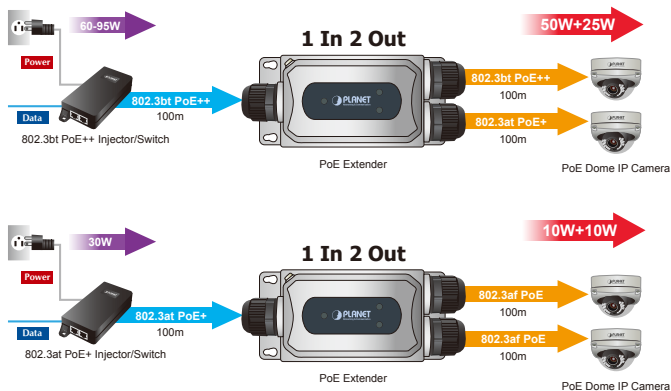

#### Note

1. According to IEEE 802.3at/bt standard, the IPOE-E302 will not inject power to the cable if not connected to a standard IEEE 802.3at/bt device.
2. **DO NOT** connect any non-standard PSE to **PoE++** In port of the IPOE-E302; it may damage the device permanently.

## 4. Power over Ethernet Budget

The following table lists how many PoE devices can be powered by the IPOE-E302 over a distance of under 1m:

Power Source	PoE Output Budget*	Max. Number of PDs supported	
		Class	Units
IEEE 802.3bt PoE++ PSE (Type 4)	90 watts max.	Class 4 PD@25.5 watts	2 units
		Class 3 PD@12.9 watts	2 units
		Class 2 PD@6.5 watts	2 units
		Class 1 PD@3.8 watts	2 units
IEEE 802.3bt PoE++ PSE (Type 3)	60 watts max.	Class 4 PD@25.5 watts	1 unit
		Class 3 PD@12.9 watts	2 units
		Class 2 PD@6.5 watts	2 units
		Class 1 PD@3.8 watts	2 units
IEEE 802.3at PoE+ PSE (Type 2)	30 watts max.	Class 4 PD@25.5 watts	1 unit
		Class 3 PD@12.9 watts	2 units
		Class 2 PD@6.5 watts	2 units
		Class 1 PD@3.8 watts	2 units

### Remarks:

1. The PoE output budget means the aggregated power output of the 2 PSE ports.
2. The aggregated power consumption will be below 60 watts if with PoE+ PSE.

### Power over Ethernet Capability

With different distance and different PoE input source, it will inflect the PoE output capability. Please refer to the table below.



### When PoE Switch (PSE) Output is DC 52V.

A (Distance)	B (Distance)	C (Watts)
60M	2M	52.7W
60M	20M	50.1 W
60M	60M	49.6W
60M	100M	44.9W
100M	2M	39W
100M	20M	37.6W
100M	60M	36.5W
100M	100M	34.6W

### When PoE Switch (PSE) Output is DC 54V.

A (Distance)	B (Distance)	C (Watts)
60M	2M	52.9W
60M	20M	50.8W
60M	60M	49.7W
60M	100M	44.9W
100M	2M	47.2W
100M	20M	45.9W
100M	60M	44.1W
100M	100M	42.2W

## When PoE Switch (PSE) Output is DC 56V.

A (Distance)	B (Distance)	C (Watts)
60M	2M	54.1W
60M	20M	53.4W
60M	60M	52.1W
60M	100M	47.4W
100M	2M	51.8W
100M	20M	49.7W
100M	60M	48.2W
100M	100M	46.7W



### Note

The table list shown here is for your reference only. The actual performance should be related to your environment.

## 5. Product Specifications

Model	IPOE-E302
Hardware Specifications	
Network Connector	<b>PoE in Port</b> - 1 x 10/100/1000BASE-T Ethernet with 802.3bt PoE++ - <b>"Data + DC"</b> in - Auto MDI/MDI-X, auto-negotiation RJ45 connector
	<b>PoE out Port</b> - 2 x 10/100/1000BASE-T Ethernet with IEEE 802.3at/bt PoE++ <b>"Data + DC"</b> out - Auto MDI/MDI-X, auto-negotiation RJ45 connector
Switch Architecture	Store-and-Forward switch architecture
MAC Address Table	2K MAC address table with auto learning function
Data Buffer	1Mbit
Switch Fabric	6Gbps
Switch Throughput	4.46Mpps @ 64Bytes
Flow Control	IEEE 802.3x pause frame for full duplex Back pressure for half duplex
Jumbo Frame	9Kbytes
ESD Protection	Air 8KV DC, Contact 6KV DC
Surge Protection	6KV
Enclosure	IP67-rated and IK10 aluminum case
Installation	Wall-mount ear
LED Display	LNK/ACT LED x 3
Dimensions (W x D x H)	150 x 43.8 x 72.94 mm 169.85 x 43.8 x 72.94 mm, with cable gland
Weight	339g 372g (with three waterproof cable glands)
Power Consumption	95.6 watts / 326.2BTU (Full loading with PoE function)



Power over Ethernet	
PoE Standard	<b>PoE in Port</b> - IEEE 802.3bt PoE++ Type 4 standard PD - IEEE 802.3bt PoE++ Type 3 standard PD - IEEE 802.3at PoE+ end-span/mid-span PD
	<b>Per PoE out Port</b> IEEE 802.3bt PoE++ end-span/mid-span PSE
PoE Power	<b>PoE in Port</b> 52~57V DC, max. 95 watts <b>Per PoE out Port</b> 50~55V DC, max. 60 watts
Power Pin Assignment	<b>PoE in Port</b> 1/2 (-), 3/6 (+), 4/5 (+), 7/8 (-) or 1/2 (+), 3/6 (-), 4/5 (+), 7/8 (-) <b>Per PoE out Port</b> 1/2 (-), 3/6 (+), 4/5 (+), 7/8 (-)
PoE Power Budget	95 watts (max.) @ 802.3bt PoE++ Type 4 input 60 watts (max.) @ 802.3bt PoE++ Type 3 input 30 watts (max.) @ IEEE 802.3at PoE+ input IEEE 802.3af PoE input not supported
Standards Conformance	
Regulatory Compliance	FCC Part 15 Class A CE
Stability Testing	IEC 60068-2-32 (Free fall) IEC 60068-2-27 (Shock) IEC 60068-2-6 (Vibration)
Standards Compliance	IEEE 802.3 Ethernet IEEE 802.3u Fast Ethernet IEEE 802.3ab Gigabit Ethernet IEEE 802.3x Flow Control IEEE 802.3af Power over Ethernet IEEE 802.3at Power over Ethernet Plus IEEE 802.3bt Power over Ethernet Plus Plus

Environment	
Operating	Temperature: -40 ~ 75 degrees C Relative Humidity: 5 ~ 95% (non-condensing)
Storage	Temperature: -40 ~ 85 degrees C Relative Humidity: 5 ~ 95% (non-condensing)

---

## **6. Customer Support**

Thank you for purchasing PLANET products. You can browse our online FAQ resource and user's manual on PLANET web site first to check if it could solve your issue. If you need more support information, please contact PLANET support team.

PLANET online FAQs:

<https://www.planet.com.tw/en/support/faq>

Support team mail address:

[support@planet.com.tw](mailto:support@planet.com.tw)

Copyright © PLANET Technology Corp. 2022.

Contents are subject to revision without prior notice.

PLANET is a registered trademark of PLANET Technology Corp.

All other trademarks belong to their respective owners.