

**Industrial 5-Port Ethernet Switch
with 4-Port PoE+**

ISW-504PT/ISW-514PTF

User's Manual

Table of Contents

1. Package Contents	3
2. Hardware Introduction	4
2.1 Switch Front Panel	4
2.2 LED Indicators	6
2.3 Switch Upper Panel	7
2.4 Wiring the Power Inputs	7
2.5 Wiring the Fault Alarm Contact	9
3. Installation	10
3.1 DIN-rail Mounting Installation	10
3.2 Wall-mount Plate Mounting	11
3.3 Side Wall-mount Plate Mounting	11
4. Troubleshooting	12
5. Customer Support	13

1. Package Contents

Thank you for purchasing PLANET 5-Port Industrial Ethernet Switch with 4-Port PoE+, ISW-504PT/ISW-514PTF. The interfaces of these models are shown below:

Model Name	10/100Mbps RJ45 Ports	100FX SFP Slots	PoE+ Ports
ISW-504PT	5	-	4
ISW-514PTF	4	1	4

In the following section, the term **“Industrial PoE+ Switch”** means the ISW-504PT/ISW-514PTF.

Open the box of the Industrial PoE+ Switch and carefully unpack it. The box should contain the following items:

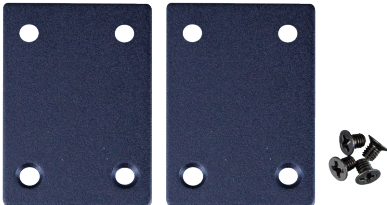
<p style="text-align: center;">Industrial PoE+ Switch x 1</p> 	<p style="text-align: center;">QR Code Sheet x 1</p> 
<ul style="list-style-type: none"> ● ISW-504PT: RJ45 Dust Cap x 5 ● ISW-514PTF: SFP Dust Cap x 1 RJ45 Dust Cap x 4 	<p style="text-align: center;">Wall-mount Kit x 1</p> 

If any of these are missing or damaged, please contact your dealer immediately.

2. Hardware Introduction

2.1 Switch Front Panel

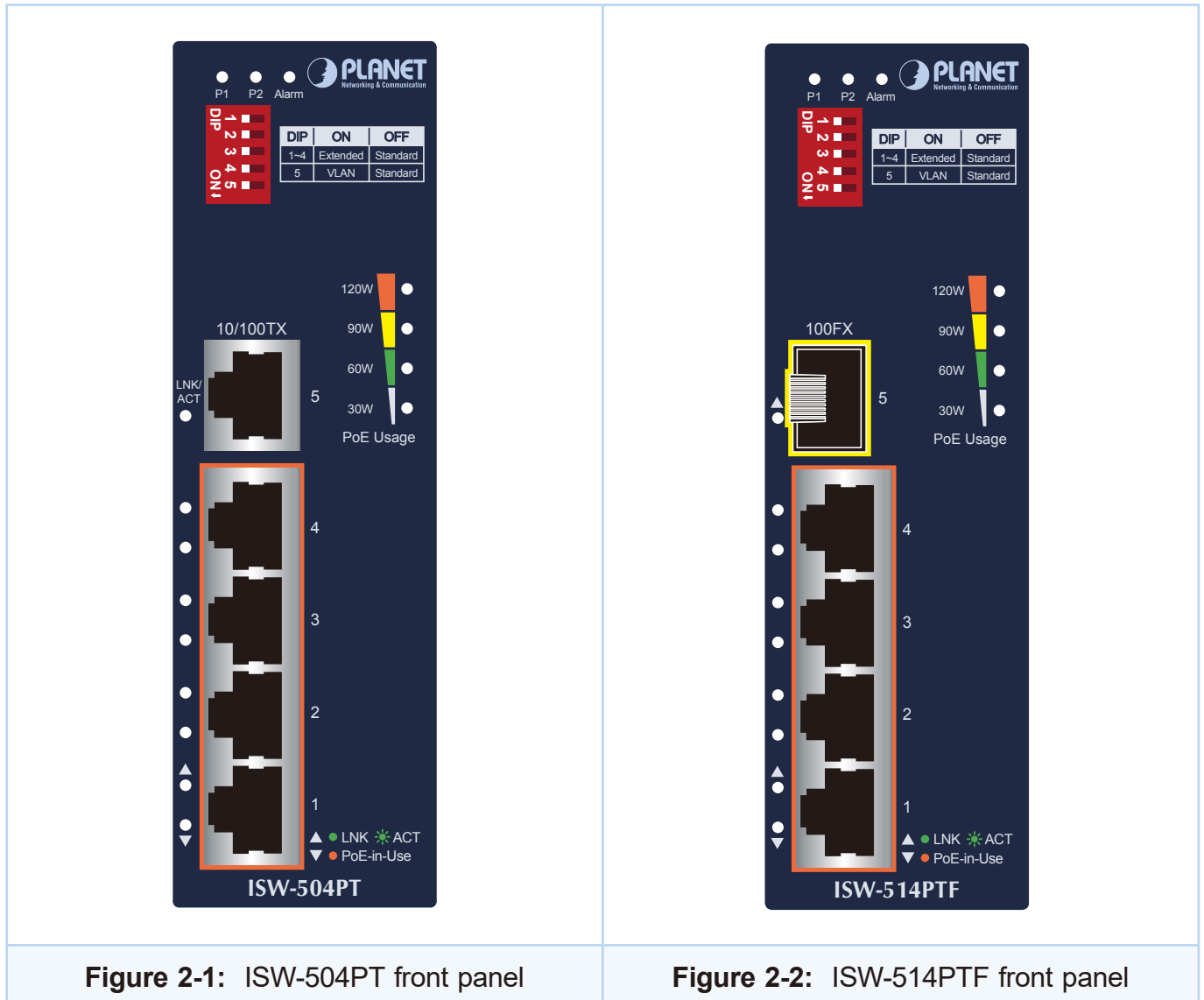

1. Fast Ethernet TP Interfaces



10/100BASE-TX copper, RJ45 twisted-pair: Up to 100 meters.

2. 100BASE-FX SFP Slot (ISW-514PTF)

100BASE-FX mini-GBIC slot, SFP (Small Factor Pluggable) transceiver module: From 2 kilometers (multi-mode fiber) to 20/40/60/120 kilometers (single-mode fiber).

3. DIP Switch

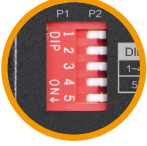
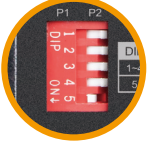
The Industrial PoE+ Switch provides one DIP switch for Standard, VLAN and Extended mode selections. The detailed descriptions are shown in the following table.

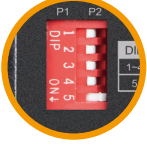
DIP Switch Mode	Function
<p>Standard</p> 	<p>Switches 1 to 5 are off</p> <p>This mode makes the Industrial PoE+ Switch operate as a general switch and all PoE ports operate at 10/100Mbps auto-negotiation.</p>
<p>VLAN</p> 	<p>Switch 5 is on</p> <p>This mode makes the Industrial PoE+ Switch operate as a VLAN isolation switch and</p> <ol style="list-style-type: none"> 1. Port 1 to 4 will isolate respectively. 2. Port 1 to 4 can only communicate with port 5. <div style="border: 1px solid #ccc; padding: 5px; margin-top: 10px;">  <p>Note After adjusting VLAN DIP switch, reboot the Industrial PoE+ Switch to make the change take effect.</p> </div>
<p>Extend</p> 	<p>Any of switches 1 to 4 is on</p> <p>This mode makes the Industrial PoE+ Switch operate on a per-port basis at 10Mbps full duplex operation but can support IEEE 802.3af PoE power output over a distance of up to 250 meters overcoming the 100m limit on Ethernet UTP cable.</p>

2.2 LED Indicators

■ System

LED	Color	Function
P1	Green	Lights: indicates power 1 has power.
P2	Green	Lights: indicates power 2 has power.
Alarm	Red	Lights: indicates either power 1 or power 2 has no power.
30W	Amber	Off: indicates the PoE usage is less than 14W. Blinks: indicates that the PoE usage is around 15W to 29W. Lights: indicates the PoE usage is around/over 30W.
60W	Amber	Blinks: indicates that the PoE usage is around 45W to 59W. Lights: indicates the PoE usage is around/over 60W.
90W	Amber	Blinks: indicates that the PoE usage is around 75W to 89W. Lights: indicates the PoE usage is around/over 90W.
120W	Amber	Blinks: indicates that the PoE usage is around 100W to 119W. Lights: indicates the PoE usage is at the maximum.

■ Per 802.3at PoE+ 10/100BASE-TX Interface (Port 1 to Port 4)

LED	Color	Function
LNK/ACT	Green	Lights: indicates the link through that port is successfully established at 10Mbps or 100Mbps. Blinks: indicates that the switch is actively sending or receiving data over that port.
PoE - in-Use	Amber	Lights: indicates the port is providing DC in-line power. Off: indicates the connected device is not a PoE powered device (PD).

■ Per 10/100BASE-TX Interface (Port 5 of ISW-504PT)

LED	Color	Function
LNK/ACT	Green	Lights: indicates the link through that port is successfully established at 10/100Mbps. Blinks: indicates that the switch is actively sending or receiving data over that port.

■ Per 100FX SFP Slot (Port 5 of ISW-514PTF)

LED	Color	Function
LNK/ACT	Green	<p>Lights: indicates the link through that port is successfully established at 100Mbps.</p> <p>Blinks: indicates that the switch is actively sending or receiving data over that port.</p>

2.3 Switch Upper Panel

The upper panel of the Industrial PoE+ Switch consists of one terminal block connector within two DC power inputs.

Figure 2-3 shows the upper panel of the Industrial PoE+ Switch.

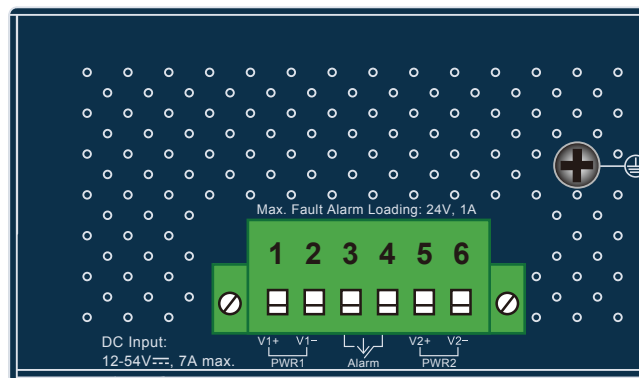

Figure 2-3: Industrial PoE+ Switch Upper Pane

2.4 Wiring the Power Inputs

The 6-contact terminal block connector on the top panel of Industrial PoE+ Switch is used for two DC redundant power inputs. Please follow the steps below to insert the power wire.



Caution

When performing any of the procedures like inserting the wires or tightening the wire-clamp screws, make sure the power is OFF to prevent from getting an electric shock.

1. Insert positive and negative DC power wires into contacts 1 and 2 for POWER 1, or 5 and 6 for POWER 2.

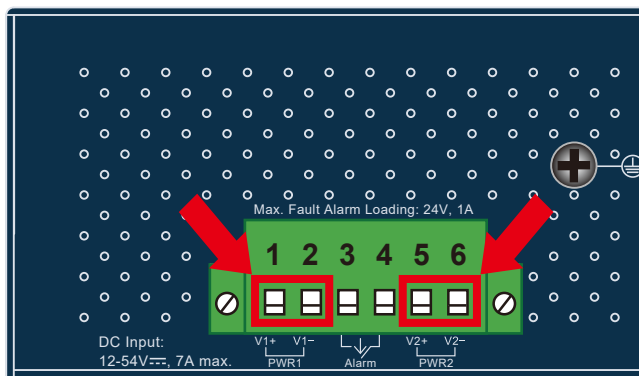

DC Input	Max. PoE Budget
12V	60W
24v	90W
48V-54V	120W



To avoid damage, please use the Industrial PoE+ Switch under its specification.

Note

2. Tighten the wire-clamp screws for preventing the wires from loosening.

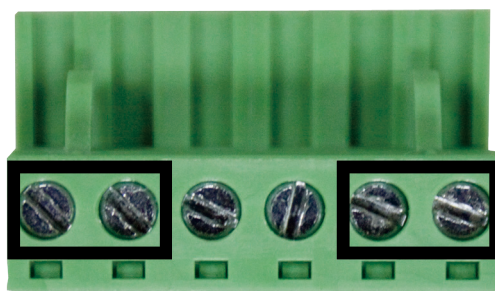

1 2 3 4 5 6
 Power 1 Alarm Power 2
 + - + -



The wire gauge for the terminal block should be in the range between 12 and 24 AWG.

Note

2.5 Wiring the Fault Alarm Contact

The fault alarm contacts are in the middle of the terminal block connector as the picture shows below. Inserting the wires, the Industrial PoE+ Switch will detect the fault status of the power failure and then forms an open circuit. The following illustration shows an application example for wiring the fault alarm contacts.

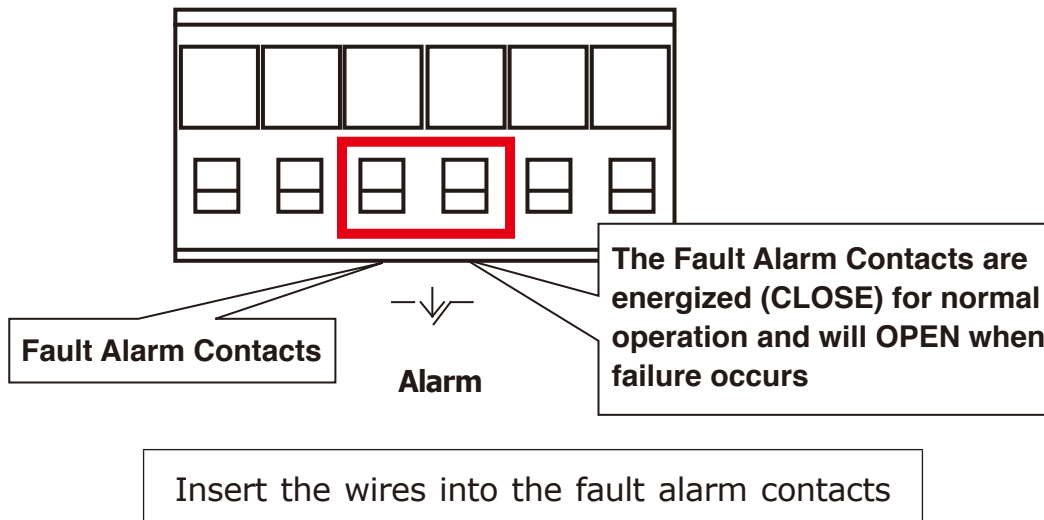

Note

1. The wire gauge for the terminal block should be in the range between 12 and 24 AWG.
2. Alarm relay circuit accepts up to 24V, max. 1A currents.

3. Installation

This section describes the functionalities of the Industrial PoE+ Switch's components and guides how to install it on the DIN-rail and wall. Basic knowledge of networking is assumed. Please read this chapter completely before continuing.



Note

The installation procedures of the ISW-504PT and ISW-514PTF are the same as they are shown below.

3.1 DIN-rail Mounting Installation

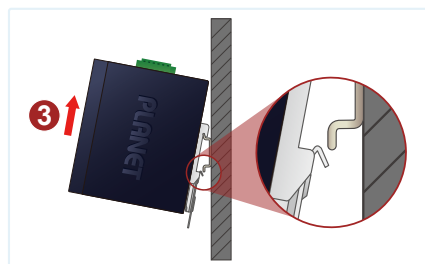
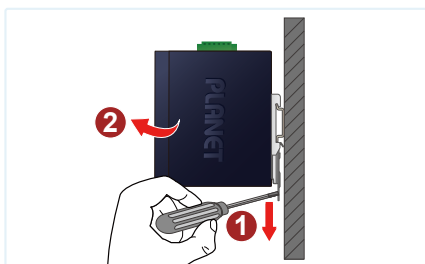
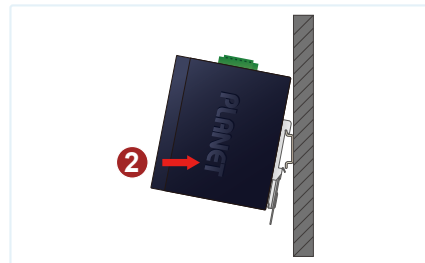
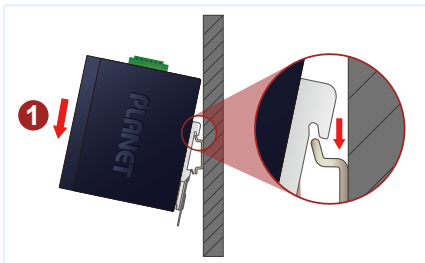
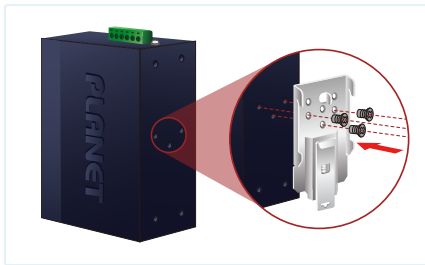

3.2 Wall-mount Plate Mounting

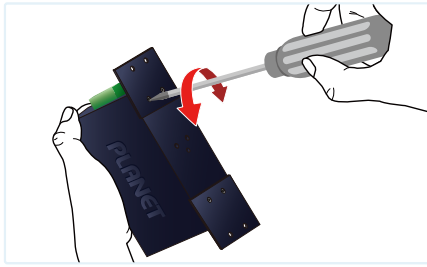

3.3 Side Wall-mount Plate Mounting

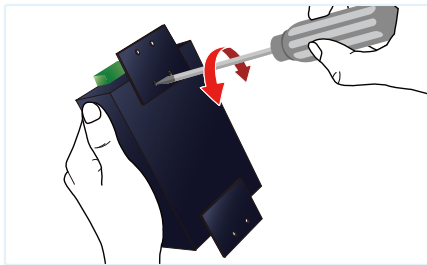

Note

You must use the screws supplied with the wall-mounting brackets. Damage caused to the parts by using incorrect screws would invalidate your warranty.

4. Troubleshooting

This chapter contains information to help you solve issues. If the Industrial PoE+ Switch is not functioning properly, make sure the Industrial PoE+ Switch was set up according to instructions in this manual.

The per port LED is not lit

Solution:

Check the cable connection of the Industrial PoE+ Switch.

Per port LED is lit, but the traffic is irregular

Solution:

Check whether the attached device is not set to dedicated full duplex. Some devices use a physical or software switch to change duplex modes. Auto-negotiation may not recognize this type of full-duplex setting.

Why the Industrial PoE+ Switch doesn't connect to the network

Solution:

Check each port LED on the Industrial PoE+ Switch. Try another port on the Industrial PoE+ Switch. Make sure the cable is installed properly and the right type. Turn off the power. After a while, turn on the power again.

I connected a PoE powered device to the Industrial PoE+ Switch, why it could not be powered on

Solution:

1. Please check the cable type of the connection from Industrial PoE+ Switch (port 1 to port 4) to the other end. The cable should be an 8-wire UTP, Category 5e or above, EIA568 cable within 100 meters. A cable with only 4-wire, short loop or over 100 meters will affect the power supply.
2. Please check and assure the PoE powered device is fully complied with IEEE 802.3at standard.

5. Customer Support

Thank you for purchasing PLANET products. You can browse our online FAQ resource at the PLANET Web site first to check if it could solve your issue. If you need more support information, please contact PLANET support team.

PLANET online FAQs:

<https://www.planet.com.tw/en/support/faq>

Support:team mail address:

support@planet.com.tw

Copyright © PLANET Technology Corp. 2024.

Contents are subject to revision without prior notice.

PLANET is a registered trademark of PLANET Technology Corp.

All other trademarks belong to their respective owners.

FCC Warning

This device has been tested and found to comply with the limits for a Class B digital device, pursuant to Part 15 of the FCC Rules. These limits are designed to provide reasonable protection against harmful interference when the equipment is operated in a commercial environment. This equipment generates, uses, and can radiate radio frequency energy and, if not installed and used in accordance with the Instruction manual, may cause harmful interference to radio communications. Operation of this equipment in a residential area is likely to cause harmful interference in which case the user will be required to correct the interference at his own expense.

CE Mark Warning

This is a Class A product. In a domestic environment, this product may cause radio interference, in which case the user may be required to take adequate measures.

This equipment is compliant with Class A of CISPR 32. In a residential environment this equipment may cause radio interference.

WEEE Warning



To avoid the potential effects on the environment and human health as a result of the presence of hazardous substances in electrical and electronic equipment, end users of electrical and electronic equipment should understand the meaning of the crossed-out wheeled bin symbol. Do not dispose of WEEE as unsorted municipal waste and have to collect such WEEE separately.